

USB-MIDI-R8

Technical Documentation



Overview

The USB-MIDI-R8 provides 8 volt free contact relay outputs with a current rating of up to 16Amp each which can be controlled via midi over USB, or a traditional DIN connector. The relays are SPCO (Single Pole Change Over) types with the normally open, normally closed and common poles available on the screw terminals.

The module is powered from a 12vdc supply which can be regulated or unregulated. The DC input jack is 2.1mm with positive core polarity, DC supplies are required to supply at least 500mA at 12vdc.

The module is supplied in a case with eyelets for wall mounting, and has an integrated clip for din rail mounting.

Operating temperature

-40C to +70C

LED indication

The lid of the case has a red LED for each relay. The LED will light when a relay is in its powered state. There is also a green LED that flashes to indicate MIDI activity, and a blue power LED.

Connections

Relay outputs 8 – 1

NO = Normally open, C = Common, NC = Normally closed

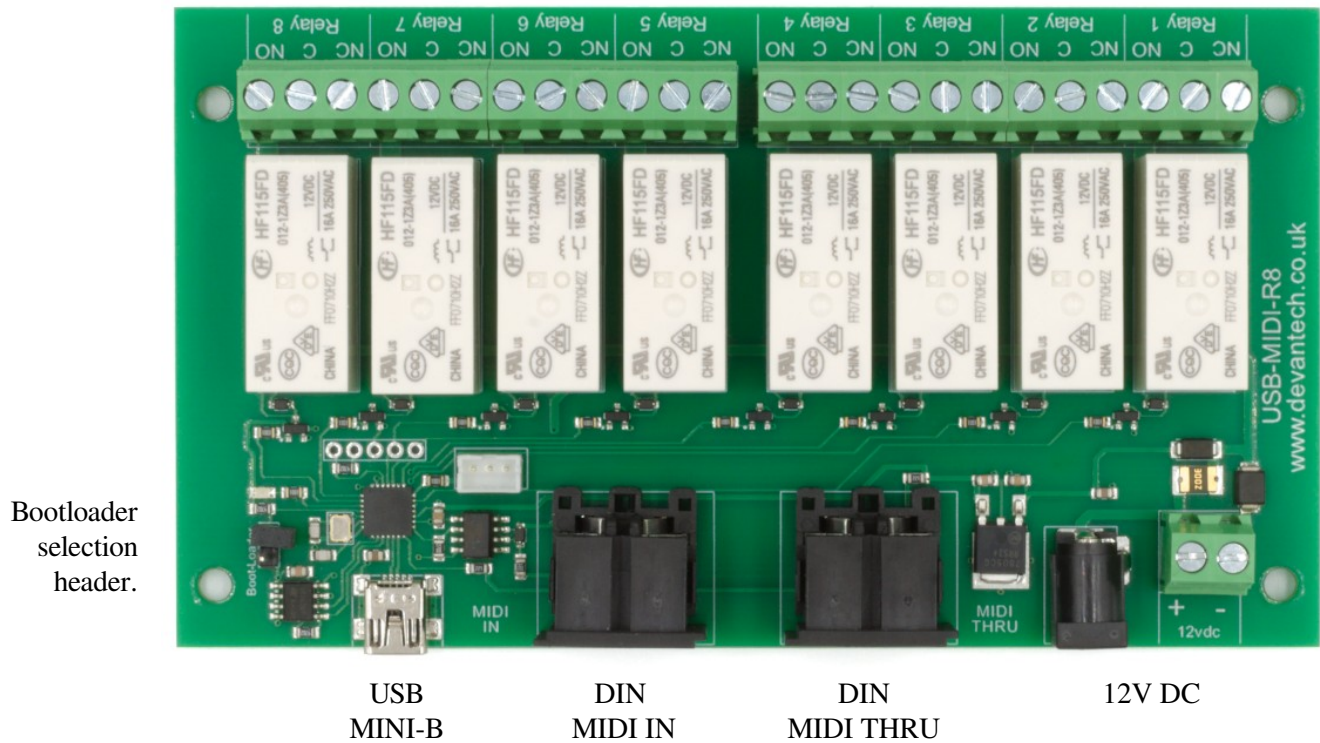

MIDI Connections

DIN MIDI IN

When connecting the USB-MIDI-R8 to your computer using the USB port the module should show up as a standard USB MIDI device that can be controlled from your DAW (Digital Audio Workstation) of your choice with no need for drivers to be installed.

A MIDI input is also available via a traditional MIDI DIN connector.

The module can not be controlled from the USB and the DIN connector at the same time. If the USB port is connected to a computer the MIDI in via the DIN connector is disabled.

DIN MIDI THRU

There is a MIDI THRU available via a DIN connector.

When controlling the module using the USB MIDI port the module port mirror any MIDI Note, or CC messages received. The module does not mirror any real-time or sysex messages that are received via USB.

When controlling the module via the MIDI DIN connection any messages received at the MIDI IN are passed straight through.

Relays

Eight 16A volt free contact relays are provided for switching a common input between a normally closed output and a normally open output. The relay coil is powered by the 12vdc incoming supply on user command.

Relay in passive state

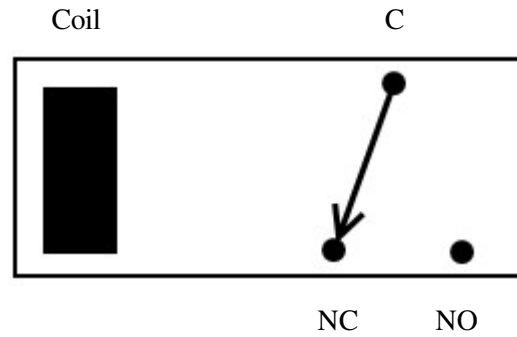

Relay in powered state

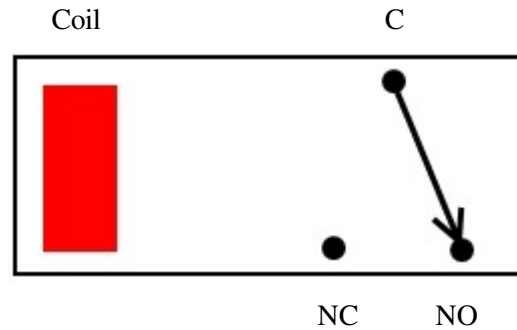

Relay power ratings

If the contact load voltage and current of the relay are in the region enclosed by the solid and dotted lines in the figure below, the relay can perform stable switching operation. If the relay is used at a voltage or current exceeding this region, the life of the contacts may be significantly shortened.

load type	Typical applications	Rating
AC1	Non inductive or slightly inductive loads	16A @ 250V AC
AC15	Control of electromagnetic load (>72VA)	3A @ 120V AC 1.5A @ 240V AC
AC3	Control of motor	750W
DC1	Non inductive or slightly inductive loads	16A @ 24V DC
DC13	Control of electromagnetic loads	0.22A @ 120V DC 0.1A @ 250V DC

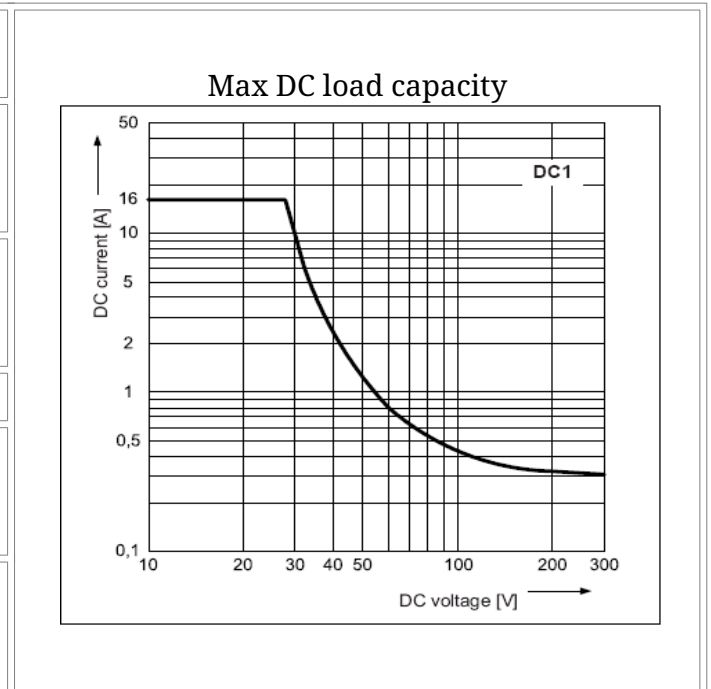

A full data sheet for the relays is here: [HF115FD datasheet](#)

Configuration

The configuration program can be downloaded from our website.

When you connect the USB-MIDI-R8 to your computer it should be found automatically. Make sure that no other software, such as a DAW, is running and connected to the module while you are updating the settings.

Once you have input your desired settings press the “update” and they will be stored on the module.

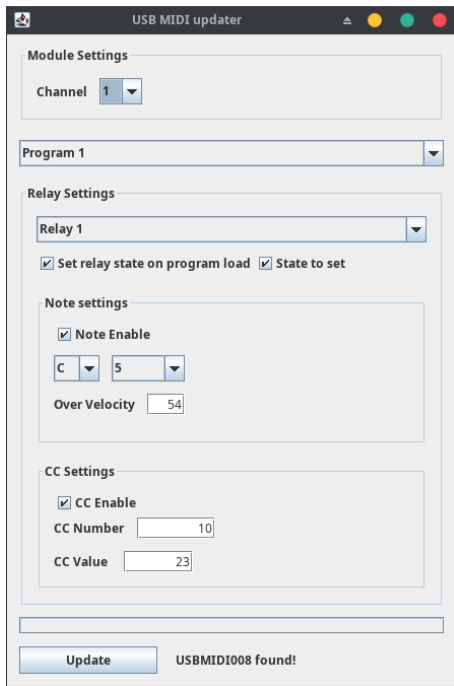

Module Settings

Channel

The Midi Channel this module will listen on.

Program

This drop down selects the program that you are currently editing. The USB-MIDI-R8 has 16 programs that can be used to store different configurations for the relays, and switched between using program change messages.

Relay Settings

Relay

This drop down selects which relay you are currently editing the settings for.

Set relay state on program load

Checking this box will set the relay to a desired state when the selected program is loaded.

State to set

Selects the state that the relay is to be set to if the “Set relay state on program load” setting is checked. Checking this box will set the relay to its powered state when the program loads. Leaving it unchecked will set the relay to the un-powered state.

Note Enable

Checking this box will make this relay respond a MIDI note. The two drop downs underneath select the note and octave. The relay will be set to its powered state when a matching note on is received, and un-powered with a note off.

Over Velocity

The value here is the velocity value over which a relay will be set to its powered state. Notes with a velocity less than this value will not change the relay state. Notes with a value greater than, or equal to, this will set the relay to its powered state.

CC Enable

Checking this box will make the relay respond to a MIDI CC message.

CC Number

Then CC number that this relay will respond to.

CC Value

A CC message with a value greater than, or equal to, this will set the relay to its powered state.

MIDI implementation

Each of the 8 relays on the module can be controlled by a single note, and CC message.

There are 16 programs available that each holds a set of relay configurations. These programs can be changed between using Program Change messages.

Midi table

Function	Transmitted	Recognised	Remark
Basic channel: Default	X	1 ~ 16	
Changed	X	X	
Mode: Default	X	Mode 3	
Message	X	Mode 3	
Note number	X	1 ~ 127	One note assigned to each relay
Control Change (CC)	X	1 ~ 127	One CC assigned to each relay
Program Change	X	O 1 ~ 16	
System Exclusive:	X	X	
System Common:			
Song Position Pointer	X	X	
Song Select	X	X	
Tune	X	X	
System Real Time:			
Clock	X	X	
Commands	X	X	
AUX Messages:			
All sounds off	X	X	
Reset all controllers	X	X	
Local on/off	X	X	
All notes off	X	X	
Active sensing	X	X	
Reset	X	X	

X: no O: yes

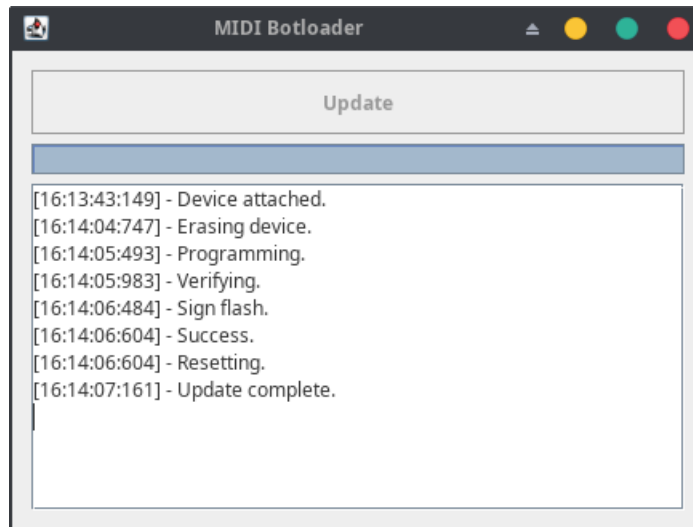

Firmware updates can be programmed into the module using our update tool while the module is in bootloader mode.

To place the module in bootloader mode power the module down, open the case, and locate the 2 pin header near the USB port.

Connect the supplied link across the 2 pin header.

When you power the module on again and connect the USB cable to your computer the green LED above the 2 pin header will start to flash; this means the module is in bootloader mode.

You can download the updater program from our website and use it to upload a new firmware to your module.

Once the firmware has been updated you should power the module down again, take the link off of the 2 pin header, replace the lid, and power the module on again.

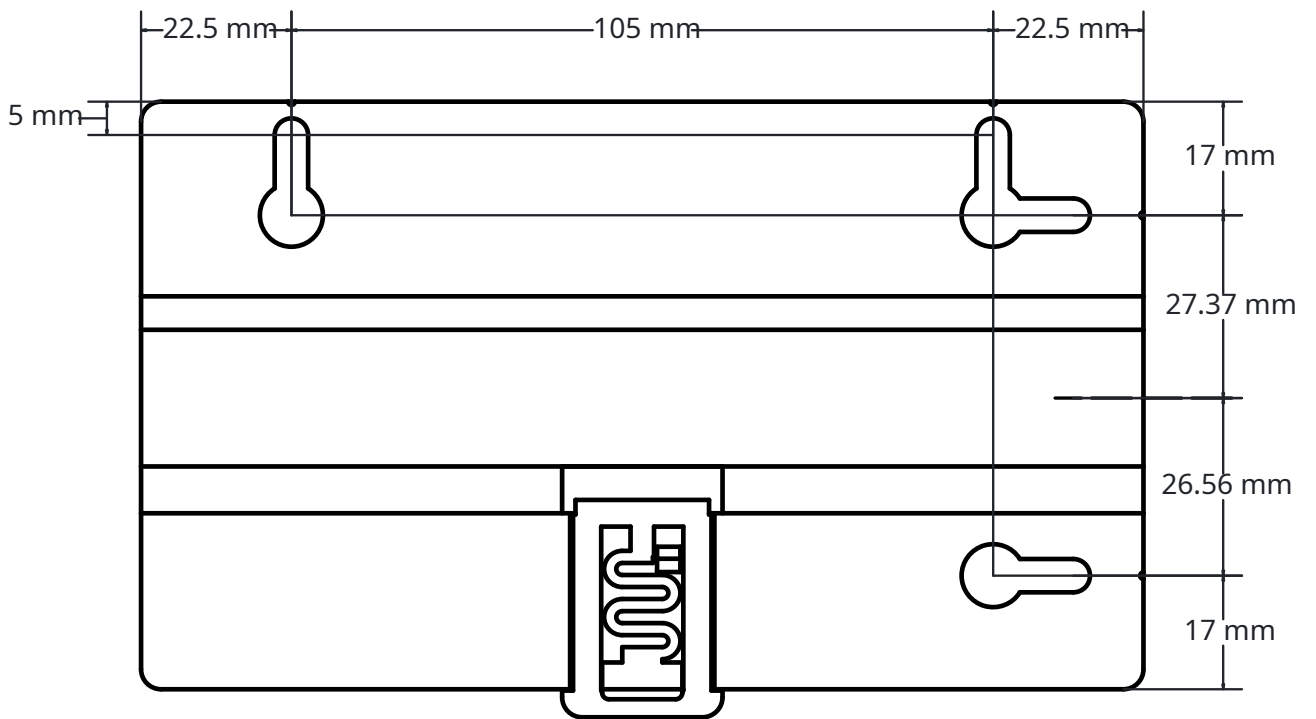
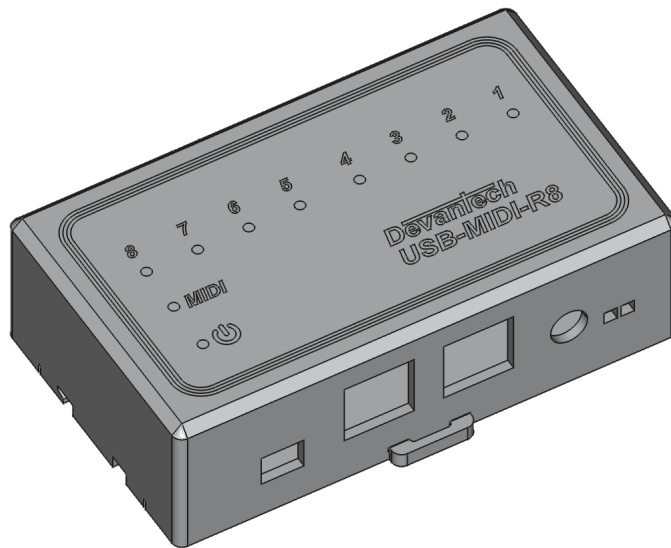

Bottom View

